

Front View

Right Side

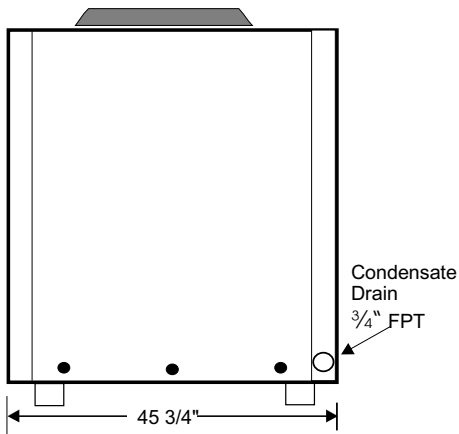

Left Side

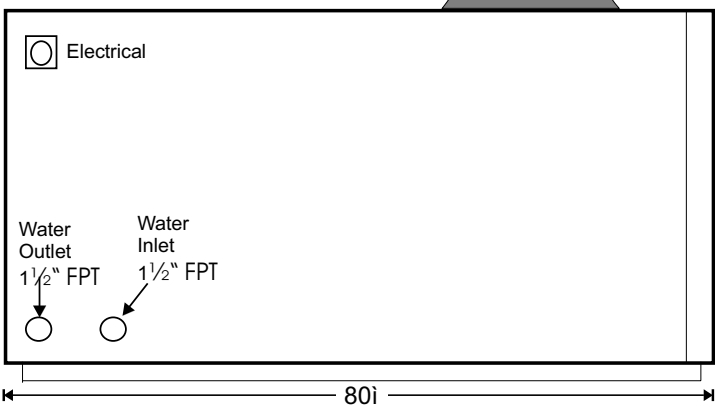

Back View

MODEL HPAS 2 SS 150

Heating Capacity	149,800 BTUH
Condenser Water Flow	30 GPM
Pressure Drop (cond.)	5.2 PSI
Entering Water Temp.	100 °F
Leaving Water Temp.	109.99 °F
COP	5.67
Compressors	(1) SM 090 Scroll
Voltage	208/230/60/3Ø
RLA/LRA	36.8
Control Voltage	24 Volts
Minimum Circuit Amp.	40 compressor

Cooling Capacity	126,000 BTUH
Evaporator Construction	Copper/Aluminum Fin
Cabinet Construction	Galvanized
Entering Wet Bulb Temp.	72.0°F
Water Pump—1/6 HP	230/1/1.08 Amp
Cooling EER	15.67
Condensers	Double Wall Vented
Construction (Cond.)	Tube-in-Tube
Fan 3/4 HP	230/60/3 - 2.8 Amp
Refrigerant Type	R-22
Minimum Unit Amperage.	50 Amp.

STANDARD FEATURES

Options

- Liquid Receiver
- Compressors Service Valves
- Liquid Line Sight Glass
- Insulated Compressor Compartment
- Compressor Adjustable Time Delay Relay
- Single Phase/Voltage Protection
- Five Year Compressor Warranty/One Yr. Parts
- Liquid Line Dryer
- Thermostatic Expansion Valves
- Hinged Control Panel
- Pre-wired Mechanical Controls
- Insulated Suction Lines
- High Side Pressure Control
- Low Side Pressure Control

- Micro-Processor Based Control System
- Painted Galvanized Cabinet
- 304 or 316 Stainless Steel Cabinet
- TechniCoat 10-1 Coated Evaporator Coil
- Blower
- Refrigerant Pump Down Solenoid Valves
- Warranty on all Parts & Labor Year 2-5

Note: In View of Continuous Product Improvements, design and specification are subject to change without Notice

Heat Harvester Energy Efficient Products
 Manufactured by
 Environmentally Engineered Equipment, Inc.

MODEL HPAS 2 SS 150													
WB TE,P	ENTERING WATER TEMP. F @ 30 GPM												
72 DEG	70	75	80	85	90	95	100	105	110	115	120	125	130
CMBTUH	144,900	142,000	139,100	135,900	132,700	129,350	126,000	122,550	119,100	115,400	111,700	107,800	103,900
HMBTUH	162,409	160,413	158,418	156,276	154,134	151,995	149,857	147,738	145,619	143,472	141,325	139,114	136,904
WATTS	5,880	6,145	6,410	6,720	7,030	7,385	7,740	8,130	8,520	8,975	9,430	9,925	10,420
EER	24.64	23.11	21.7	20.22	18.88	17.52	16.28	15.07	13.98	12.86	11.85	10.86	9.97
COP	8.09	7.65	7.24	6.81	6.42	6.03	5.67	5.32	5.01	4.68	4.39	4.11	3.85
LV. WTR	80.83	85.7	90.57	95.42	100.28	105.14	109.99	114.85	119.71	124.57	129.43	134.28	139.13
WB TE,P	ENTERING WATER TEMP. F @ 30 GPM												
67 DEG	70	75	80	85	90	95	100	105	110	115	120	125	130
CMBTUH	133,200	130,500	127,800	124,850	121,900	118,800	115,700	112,450	109,200	105,750	102,300	98,700	95,100
HMBTUH	150,709	148,930	147,152	145,260	143,368	141,479	139,591	137,689	135,787	133,890	131,993	130,117	128,240
WATTS	5,880	6,150	6,420	6,730	7,040	7,395	7,750	8,145	8,540	8,995	9,450	9,955	10,460
EER	22.65	21.22	19.91	18.55	17.32	16.06	14.93	13.81	12.79	11.76	10.83	9.91	9.09
COP	7.51	7.1	6.72	6.32	5.97	5.61	5.28	4.95	4.66	4.36	4.09	3.83	3.59
LV. WTR	80.05	84.93	89.81	94.69	99.56	104.44	109.31	114.18	119.06	123.93	128.8	133.68	138.55
WB TE,P	ENTERING WATER TEMP. F @ 30 GPM												
62 DEG	70	75	80	85	90	95	100	105	110	115	120	125	130
CMBTUH	121,500	119,000	116,500	113,800	111,100	108,250	105,400	102,350	99,300	96,100	92,900	89,600	86,300
HMBTUH	139,009	137,447	135,886	134,244	132,602	130,964	129,325	127,640	125,956	124,308	122,661	121,119	119,577
WATTS	5,880	6,155	6,430	6,740	7,050	7,405	7,760	8,160	8,560	9,015	9,470	9,985	10,500
EER	20.66	19.33	18.12	16.88	15.76	14.62	13.58	12.54	11.6	10.66	9.81	8.97	8.22
COP	6.93	6.54	6.19	5.84	5.51	5.18	4.88	4.58	4.31	4.04	3.8	3.55	3.34
LV. WTR	79.27	84.17	89.06	93.95	98.84	103.73	108.63	113.51	118.4	123.29	128.18	133.08	137.97
WB TE,P	ENTERING WATER TEMP. F @ 30 GPM												
57 DEG	70	75	80	85	90	95	100	105	110	115	120	125	130
CMBTUH	110,600	108,250	105,900	103,400	100,900	98,250	95,600	92,800	90,000	87,050	84,100	81,050	78,000
HMBTUH	128,075	126,663	125,252	123,827	122,402	120,981	119,559	118,142	116,724	115,327	113,930	112,637	111,345
WATTS	5,870	6,145	6,420	6,735	7,050	7,410	7,770	8,175	8,580	9,035	9,490	10,005	10,520
EER	18.84	17.62	16.5	15.35	14.31	13.26	12.3	11.35	10.49	9.63	8.86	8.1	7.41
COP	6.39	6.04	5.72	5.39	5.09	4.78	4.51	4.23	3.99	3.74	3.52	3.3	3.1
LV. WTR	78.54	83.45	88.35	93.26	98.16	103.07	107.97	112.88	117.78	122.69	127.6	132.51	137.43
WB TE,P	ENTERING WATER TEMP. F @ 30 GPM												
52 DEG	70	75	80	85	90	95	100	105	110	115	120	125	130
CMBTUH	100,400	98,250	96,100	93,800	91,500	89,050	86,600	84,000	81,400	78,700	76,000	73,150	70,300
HMBTUH	117,840	116,646	115,452	114,227	113,002	111,781	110,559	109,359	108,158	107,028	105,898	104,823	103,747
WATTS	5,860	6,140	6,420	6,735	7,050	7,410	7,770	8,180	8,590	9,050	9,510	10,030	10,550
EER	17.13	16	14.97	13.93	12.98	12.02	11.15	10.27	9.48	8.7	7.99	7.29	6.66
COP	5.89	5.57	5.27	4.97	4.7	4.42	4.17	3.92	3.69	3.47	3.26	3.06	2.88
LV. WTR	77.86	82.78	87.7	92.62	97.54	102.46	107.37	112.29	117.21	122.14	127.06	131.99	136.92
WB TE,P	ENTERING WATER TEMP. F @ 30 GPM												
47 DEG	70	75	80	85	90	95	100	105	110	115	120	125	130
CMBTUH	90,900	88,900	86,900	84,750	82,600	80,350	78,100	75,700	73,300	80,800	88,300	75,750	63,200
HMBTUH	108,306	107,262	106,218	105,143	104,068	103,064	102,059	101,059	100,058	109,145	118,232	107,457	96,682
WATTS	5,850	6,130	6,410	6,725	7,040	7,405	7,770	8,180	8,590	9,055	9,520	10,040	10,560
EER	15.54	14.5	13.56	12.6	11.73	10.85	10.05	9.25	8.53	8.92	9.28	7.54	5.98
COP	5.42	5.13	4.86	4.58	4.33	4.08	3.85	3.62	3.41	3.53	3.64	3.14	2.68
LV. WTR	77.22	82.15	87.08	92.01	96.94	101.87	106.81	111.74	116.67	122.28	127.89	132.17	136.45
WB TE,P	ENTERING WATER TEMP. F @ 30 GPM												
42 DEG	70	75	80	85	90	95	100	105	110	115	120	125	130
CMBTUH	82,000	80,150	78,300	76,350	74,400	72,300	70,200	68,000	65,800	63,550	61,300	58,700	56,100
HMBTUH	99,338	98,444	97,549	96,709	95,868	95,014	94,159	93,359	92,558	91,912	91,266	90,441	89,616
WATTS	5,830	6,110	6,390	6,715	7,040	7,405	7,770	8,180	8,590	9,060	9,530	10,050	10,570
EER	14.07	13.12	12.25	11.37	10.57	9.76	9.03	8.31	7.66	7.01	6.43	5.84	5.31
COP	4.99	4.72	4.47	4.22	3.99	3.76	3.55	3.34	3.16	2.97	2.81	2.64	2.48
LV. WTR	76.63	81.57	86.51	91.45	96.39	101.34	106.28	111.23	116.17	121.13	126.09	131.03	135.98