

Front View

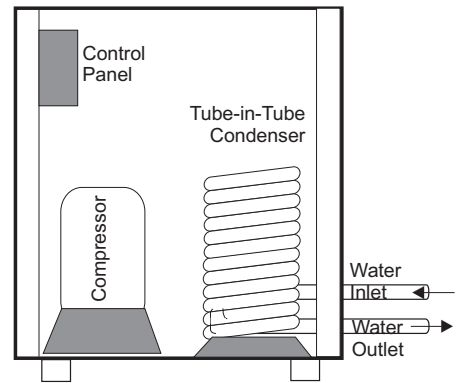

Right Side

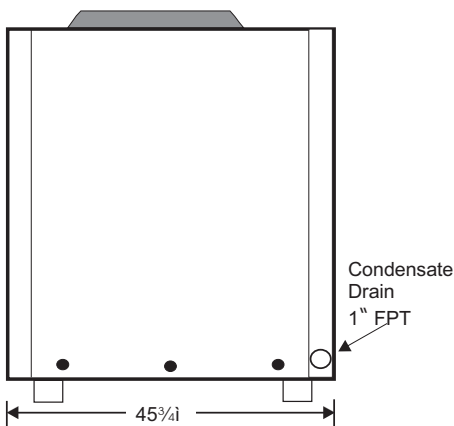

Left Side

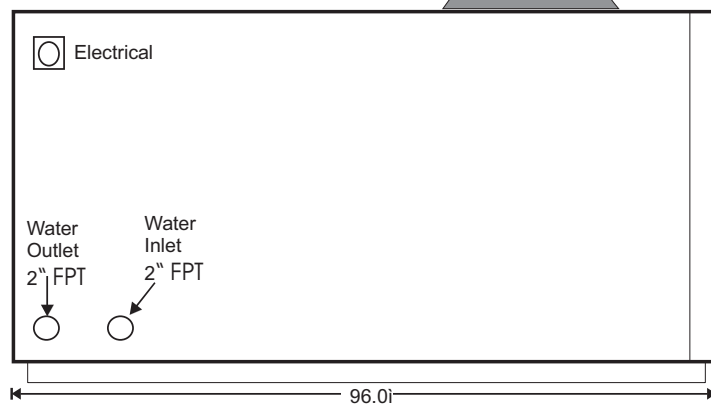

Back View

MODEL HPAS 5 SR 205

Heating Capacity	204,800 BTUH
Condenser Water Flow	60 GPM
Pressure Drop (cond.)	5.2 PSI
Entering Water Temp.	100 °F
Leaving Water Temp.	106.83 °F
COP	3.83
Compressors	(1)MTE 160 Reciprocating
Voltage	460/60/3Ø
RLA/LRA	18.76/130
Control Voltage	24 Volts
Min. Comp. Circuit Amp.	30

Cooling Capacity	166,500 BTUH
Evaporator Construction	Copper/Aluminum Fin
Cabinet Construction	Galvanize Steel
Entering Wet Bulb Temp.	72.0°F
Water Pump—1 HP	460/3/60 - 1.7 Amp
Cooling EER	13.08
Condensers	Double Wall Vented
Construction (Cond.)	Tube-in-Tube
Fan 1 HP	460/3/60 - 1.8 Amp
Refrigerant Type	R-134A
Minimum Unit Amperage.	60 Amp.

STANDARD FEATURES

- | | |
|---|-------------------------------|
| Liquid Receiver | Liquid Line Dryer |
| Compressors Service Valves | Thermostatic Expansion Valves |
| Liquid Line Sight Glass | Hinged Control Panel |
| Insulated Compressor Compartment | Pre-wired Mechanical Controls |
| Time Delay for Compressors | Insulated Suction Lines |
| Single Phase Protection | High Side Pressure Control |
| Five Year Compressor Warranty/One Yr. Parts | Low Side Pressure Control |

Options

- Micro-Processor Based Control System
- Painted Galvanize
- 304 or 316 Stainless Steel
- TechniCoat 10-1 Coated Evaporator Coil
- Blower
- Refrigerant Pump Down Solenoid Valves
- Warranty on all Parts & Labor Year 2-5

Note: In View of Continuous Product Improvements, design and specification are subject to change without Notice

Heat Harvester Energy Efficient Products
 Manufactured by
H H Systems, Inc.

MODEL HPAS 5 SR 205															
WB TEMP. ENTER WATER TEMP. F @ 50 GPM,															
72 DEG .	70	75	80	85	90	95	100	105	110	115	120	125	130	135	140
CMBTUH	203,853	197,628	191,403	185,178	178,954	172,729	166,504	159,813	153,121	146,430	139,738	133,047	126,355	119,664	112,972
HMBTUH	233,939	229,089	224,236	219,386	214,535	209,685	204,832	199,438	194,043	188,649	183,254	177,860	172,465	167,071	161,676
WATTS	10,315	10,718	11,120	11,523	11,925	12,328	12,730	13,110	13,490	13,870	14,250	14,630	15,010	15,390	15,770
EER	19.76	18.44	17.21	16.07	15.01	14.01	13.08	12.19	11.35	10.56	9.81	9.09	8.42	7.78	7.16
COP	5.79	5.4	5.04	4.71	4.4	4.11	3.83	3.57	3.33	3.09	2.87	2.66	2.47	2.28	2.1
LV. WTR	77.8	82.64	87.48	92.32	97.15	101.99	106.83	111.65	116.47	121.29	126.11	130.93	135.75	140.57	145.39
WB TEMP. ENTER WATER TEMP. F @ 50 GPM,															
67 DEG .	70	75	80	85	90	95	100	105	110	115	120	125	130	135	140
CMBTUH	183,633	177,806	171,979	166,151	160,324	154,497	148,670	142,469	136,268	130,066	123,865	117,664	111,463	105,261	99,060
HMBTUH	213,370	208,793	204,215	199,636	195,062	190,484	185,906	180,845	175,784	170,718	165,657	160,596	155,535	150,470	145,409
WATTS	10,213	10,579	10,945	11,311	11,678	12,044	12,410	12,744	13,078	13,411	13,745	14,079	14,413	14,746	15,080
EER	17.98	16.81	15.71	14.69	13.73	12.83	11.98	11.18	10.42	9.7	9.01	8.36	7.73	7.14	6.57
COP	5.27	4.92	4.6	4.3	4.02	3.76	3.51	3.28	3.05	2.84	2.64	2.45	2.27	2.09	1.92
LV. WTR	77.12	81.96	86.81	91.66	96.5	101.35	106.2	111.03	115.86	120.69	125.52	130.36	135.19	140.02	144.85
WB TEMP. ENTER WATER TEMP. F @ 50 GPM,															
62 DEG .	70	75	80	85	90	95	100	105	110	115	120	125	130	135	140
CMBTUH	163,413	157,984	152,554	147,125	141,695	136,266	130,836	125,125	119,414	113,703	107,992	102,281	96,570	90,859	85,148
HMBTUH	192,799	188,496	184,193	179,890	175,586	171,283	166,980	162,252	157,520	152,792	148,061	143,333	138,601	133,873	129,142
WATTS	10,110	10,440	10,770	11,100	11,430	11,760	12,090	12,378	12,665	12,953	13,240	13,528	13,815	14,103	14,390
EER	16.16	15.13	14.16	13.25	12.4	11.59	10.82	10.11	9.43	8.78	8.16	7.56	6.99	6.44	5.92
COP	4.74	4.43	4.15	3.88	3.63	3.4	3.17	2.96	2.76	2.57	2.39	2.22	2.05	1.89	1.73
LV. WTR	76.43	81.29	86.14	91	95.86	100.71	105.57	110.41	115.25	120.1	124.94	129.78	134.62	139.46	144.31
WB TEMP. ENTER WATER TEMP. F @ 50 GPM,															
57 DEG .	70	75	80	85	90	95	100	105	110	115	120	125	130	135	140
CMBTUH	146,231	141,146	136,062	130,977	125,892	120,807	115,722	110,436	105,149	99,863	94,576	89,290	84,003	78,717	73,430
HMBTUH	174,945	170,870	166,796	162,721	158,650	154,575	150,500	146,064	141,627	137,188	132,750	128,314	123,877	119,438	115,000
WATTS	9,913	10,209	10,505	10,801	11,098	11,394	11,690	11,939	12,188	12,436	12,685	12,934	13,183	13,431	13,680
EER	14.75	13.83	12.95	12.13	11.34	10.6	9.9	9.25	8.63	8.03	7.46	6.9	6.37	5.86	5.37
COP	4.32	4.05	3.79	3.55	3.32	3.11	2.9	2.71	2.53	2.35	2.18	2.02	1.87	1.72	1.57
LV. WTR	75.83	80.7	85.56	90.43	95.29	100.15	105.02	109.87	114.72	119.57	124.43	129.28	134.13	138.98	143.83
WB TEMP. ENTER WATER TEMP. F @ 50 GPM,															
52 DEG .	70	75	80	85	90	95	100	105	110	115	120	125	130	135	140
CMBTUH	146,231	141,146	136,062	130,977	125,892	120,807	115,722	110,436	105,149	99,863	94,576	89,290	84,003	78,717	73,430
HMBTUH	174,269	170,081	165,892	161,704	157,513	153,326	149,135	144,566	139,996	135,426	130,856	126,287	121,717	117,147	112,577
WATTS	9,715	9,978	10,240	10,503	10,765	11,028	11,290	11,500	11,710	11,920	12,130	12,340	12,550	12,760	12,970
EER	15.05	14.15	13.29	12.47	11.69	10.95	10.25	9.6	8.98	8.38	7.8	7.24	6.69	6.17	5.66
COP	4.41	4.14	3.89	3.65	3.43	3.21	3	2.81	2.63	2.45	2.28	2.12	1.96	1.81	1.66
LV. WTR	75.81	80.67	85.53	90.39	95.25	100.11	104.97	109.82	114.67	119.52	124.36	129.21	134.06	138.91	143.75
WB TEMP. ENTER WATER TEMP. F @ 50 GPM,															
47 DEG .	70	75	80	85	90	95	100	105	110	115	120	125	130	135	140
CMBTUH	129,050	124,309	119,569	114,829	110,089	105,348	100,608	95,746	90,884	86,022	81,160	76,298	71,436	66,574	61,712
HMBTUH	157,088	153,244	149,399	145,556	141,710	137,867	134,021	129,876	125,731	121,585	117,440	113,295	109,150	105,004	100,859
WATTS	9,715	9,978	10,240	10,503	10,765	11,028	11,290	11,500	11,710	11,920	12,130	12,340	12,550	12,760	12,970
EER	13.28	12.46	11.68	10.93	10.23	9.55	8.91	8.33	7.76	7.22	6.69	6.18	5.69	5.22	4.76
COP	3.89	3.65	3.42	3.2	3	2.8	2.61	2.44	2.27	2.11	1.96	1.81	1.67	1.53	1.39
LV. WTR	75.24	80.11	84.98	89.85	94.73	99.6	104.47	109.33	114.19	119.05	123.92	128.78	133.64	138.5	143.36
WB TEMP. ENTER WATER TEMP. F @ 50 GPM,															
42 DEG .	70	75	80	85	90	95	100	105	110	115	120	125	130	135	140
CMBTUH	114,578	110,134	105,690	101,246	96,802	92,358	87,914	83,470	78,921	74,424	69,927	65,430	60,934	56,437	51,940
HMBTUH	141,643	138,001	134,359	130,717	127,075	123,433	119,791	115,895	112,003	108,107	104,211	100,314	96,422	92,526	88,630
WATTS	9,430	9,665	9,900	10,135	10,370	10,605	10,840	11,016	11,193	11,369	11,545	11,721	11,898	12,074	12,250
EER	12.15	11.4	10.68	9.99	9.33	8.71	8.11	7.57	7.05	6.55	6.06	5.58	5.12	4.67	4.24
COP	3.56	3.34	3.13	2.93	2.74	2.55	2.38	2.22	2.07	1.92	1.77	1.64	1.5	1.37	1.24
LV. WTR	74.72	79.6	84.48	89.36	94.24	99.12	103.99	108.86	113.73	118.61	123.48	128.35	133.22	138.09	142.96